

# MTMA70 Plus

## Mobility made easy.

Constructed out of high-grade aluminum, the MTMA Plus series provides a mobile mounting solution that is highly durable and lightweight. Each mount comes with a VESA compatible mounting bracket, component tray and upper shelf, allowing you to safely and effortlessly maneuver your TV and accessories. Complementing today's modern TVs, their sleek appearance and integrated cable management make them perfectly suited for any home, school or office environment. Every MTMA Plus unit offers simple height adjustment and quick-release wheel locks, and comes packaged in a heavy-duty, compact box to allow for safe and easy transport. Available in three models to accommodate a wide range of TV sizes.



## FEATURES & SPECIFICATIONS

- Fits most flat panel TVs from 40" to 70"
- Supports TVs up to 100 lb (45 kg)
- Accommodates VESA sizes from 100x100 to 600x400
- Height adjustable between 47" (1.2 m) and 59" (1.5 m)
- Integrated cable management system
- Lightweight but sturdy aluminum body
- Convenient accessory tray and top shelf for storage of remotes, AV equipment and webcam
- Four wheel locks can be applied and released with your foot
- Assembly manual and all TV mounting hardware is included
- Five year warranty
- Shipping box weight: 48.5 lb (22 kg)
- Shipping box dimensions: 34.4" x 19.1" x 9.1" (87.3 x 48.5 x 23 cm)
- Product weight: 42 lb (19.1 kg)
- UPC: 800152715179

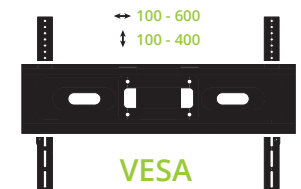
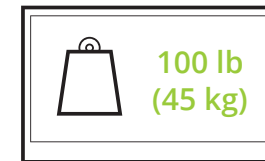
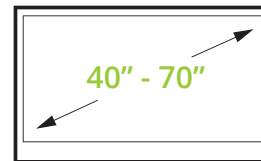



### FITS VESA SIZES TO 600X400

MTMA70 Plus is designed to fit most flat panel TVs from 40" to 70", with VESA sizes ranging from 100x100 to 600x400



### ADJUSTABLE MIDDLE TRAY

MTMA70 Plus includes an adjustable middle tray that can hold up to 10 pounds (4.5 kg), making it perfectly suited for your laptop, PVR, or other AV hardware.



### EASY HEIGHT ADJUSTMENT

Using the provided Allen key, easily adjust the center of your TV anywhere between 47" (1.2m) and 59" (1.5m) to find the perfect viewing height. This adjustment should be done with the TV removed.



### TOP SHELF

The top shelf is ideal for placing a camera, making the MTMA70 Plus a perfect display unit for web conferences.



### UNIQUE CABLE MANAGEMENT

Built with a hollow tower, MTMA70 Plus allows you to hide your cables for a clean and professional appearance. Grommets are also provided to keep your cables securely in place.



### EVERYTHING YOU NEED

MTMA70 Plus comes packaged in a compact box with all the mounting bolts, washers and spacers you'll need to secure your TV in place.

## TECHNICAL ILLUSTRATIONS

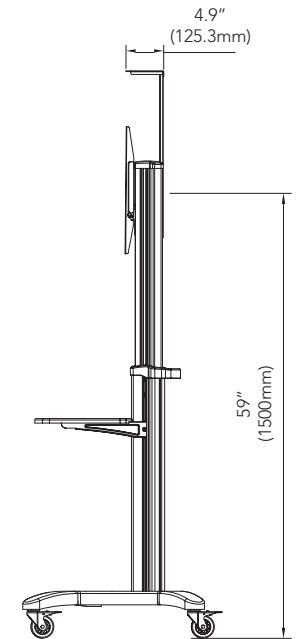
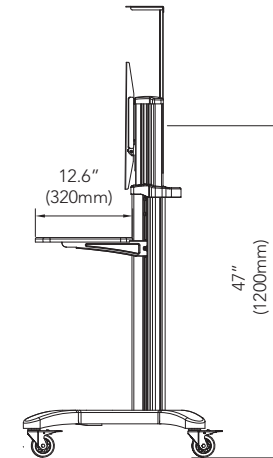
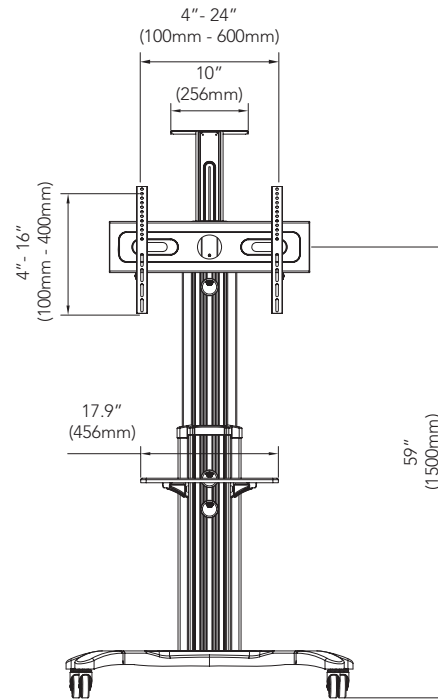
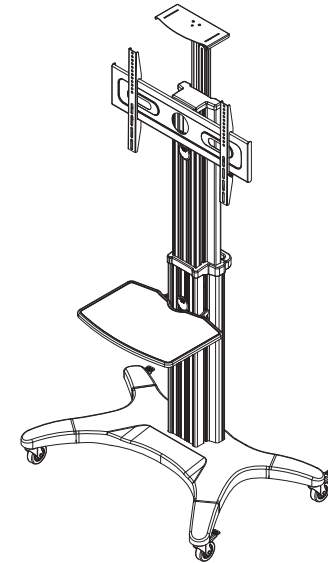
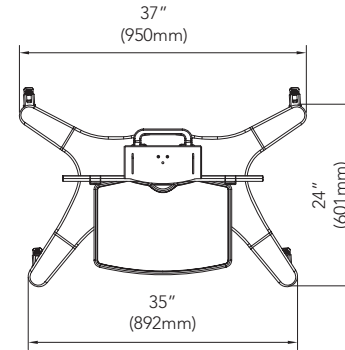

[www.kantoliving.com](http://www.kantoliving.com) | [sales@kantoliving.com](mailto:sales@kantoliving.com)

Supporting your digital lifestyle™

Kanto Living 2390 Canoe Avenue, Coquitlam, BC, V3K 6C2  
office: 778.284.6942 | fax: 778.284.6945 | toll free: 888.848.2643